

BOSSCHARGER

EV CHARGING STATION

User's Manual

*Please read the instructions carefully before using.





Table of Contents

Safety Caution	1
Product Introduction	2
Product Features	3
Main Parameters	4
Installation Instructions	5
Check and Debug the Device	7
Charging Operation	8
Wi-Fi Function Usage	9
Charging Status & Indicators	13
Troubleshooting	13



Safety **Caution** (*Please save these instructions)

1. Do not put inflammable, explosive or combustible materials, chemicals, combustible steam and other dangerous articles near the charging pile;
2. Keep vehicle connector clean and dry. If there is dirt, please use a clean dry cloth to wipe, do not touch the vehicle connector core when the power is on;
3. It is strictly forbidden to use the charging pile when the vehicle connector or charging cable has defects, cracks, wear, breakage or bare charging cable. If you find any defects, please contact the staff in time;
4. Do not attempt to disassemble, repair or modify the charging pile. If you need to repair or modify the charging pile, please contact the staff. Improper operation may cause equipment damage, water leakage, electricity leakage and other situations;
5. Press the emergency stop button immediately to cut off all input and output power in case of any abnormal situation during use;
6. In case of rain or thunder, please charge with caution;
7. Children are not allowed to get close to or use the charging pile during charging to avoid injury
8. During the charging process, the vehicle is forbidden to run and can only be charged when it is stationary. Please turn off the hybrid electric car and then charge it.
9. During charging, the current cannot be adjusted. Only the charger is pulled out and set again. If you want to set the charging start time, please turn off the Auto-Start.
10. The maximum current of this vehicle connector is 32A and at least 40A breaker needs to be installed by a professional electrician.

Product Introduction

The product is a single-phase/three-phase EV Charging Station, mainly used for AC charging. The product works by swiping card or Wi-Fi, and contains charging protection, etc. The equipment adopts the principle of industrial design, to ensure the safety of equipment operation. The protection grade of the whole machine reaches IP65, with good dust-proof and water-proof functions, and can be operated and maintained safely outdoors.

Product Appearance



Fig 1 Appearance

Functional Block Diagram

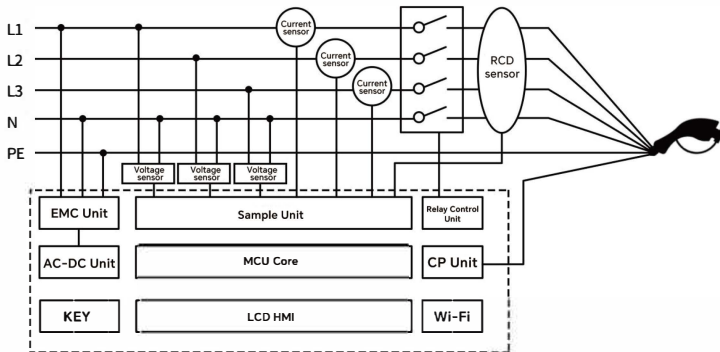

Fig.2 Electrical schematic diagram

Product **Features**



Modular design, stable and reliable

the equipment adopts modular design principle, flexible configuration, convenient maintenance.



All-round protection, safe operation

with over-voltage protection, over-current protection, leakage protection, grounding protection, over-temperature protection, lightning protection, CP abnormal detection to ensure the safe and reliable operation of equipment, effectively prevent accidents.



Convenient use

convenient installation and more convenient use.



High protection grade

IP65 protection grade, supports the outdoor environment, but indoor using environment is recommended for a longer life span.



Low power consumption

low standby power consumption to 5W, low energy consumption.



Compatibility

The device is a simple home version that can be software-configured to operate in “Auto start” mode, requiring only software set-up and no hardware modification.



Compact structure small space and light.



Main Parameters

Specifications	Model	PEV-7KW03EN	PEV-11KW03EN	PEV-21KW03EN
Appearance Material	Size	385x 284 x 80 (mm)		
	Net Weight	~4.1kg	~3.6kg	~5.0kg
	Cable Length	5m		
Electrical Indicators	Input/Output Voltage	230VAC 50/60Hz 1Phase	400VAC 50/60Hz 3Phase	
	Input/Output Current	32A Max	16A Max	32A Max
	RCD	Type A+DC 6mA		
	Output Power	7kW Max	11kW Max	22kW Max
	Standby Power	<5W		
	Certification	CE/FCC		
	Standard	EN 61851-1		
	Charge Interface	EN 62196 Type 2		
	User Interface	LED/LCD/RFID/Wi-Fi		
Environmental Indicators	Operating temperature	-30 C ~+50 C		
	Humidity	Max.95%(non-regulating)		
	Altitude	≤2000m		
	IP Class	IP65		
	Cool mode	Natural cooling		
Safety Design	<p>Overvoltage Protection</p> <p>UnderVoltage Protection</p> <p>Overcurrent Protection</p> <p>Residual Current Protection</p> <p>Over Temperature Protection</p> <p>CP Protection</p> <p>Lightning Protection</p>			

Installation Instruction

Step1 (Fig.4)

Fix the wall bracket (included) on the wall and keep the height from the ground at about 1280mm.

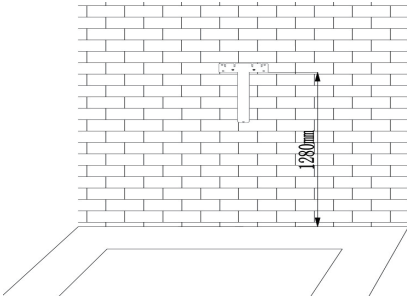

Fig. 4

Step3 (Fig.6)

Wall-mounted installation and fixation: Mount the rear mounting hole of the device from the front side to the wall fixing screw, and fix it;

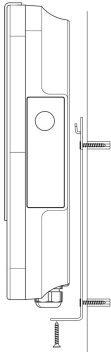

Fig.6

Step2 Wiring (Fig.5)

- 1) Plug-in. Plug the cable in the socket and power the device;
- 2) Hard wiring. A professional electrician is required to operate hard wiring.

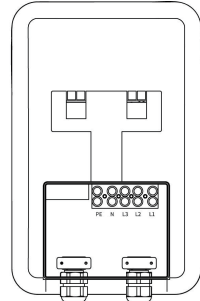

Fig. 5

Step4 (Fig.7)

Mounting the charging holster under the equipment and keep the height from the ground at about 800mm.

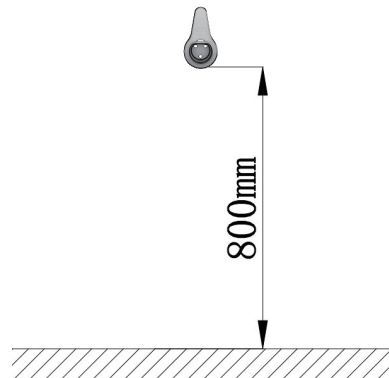
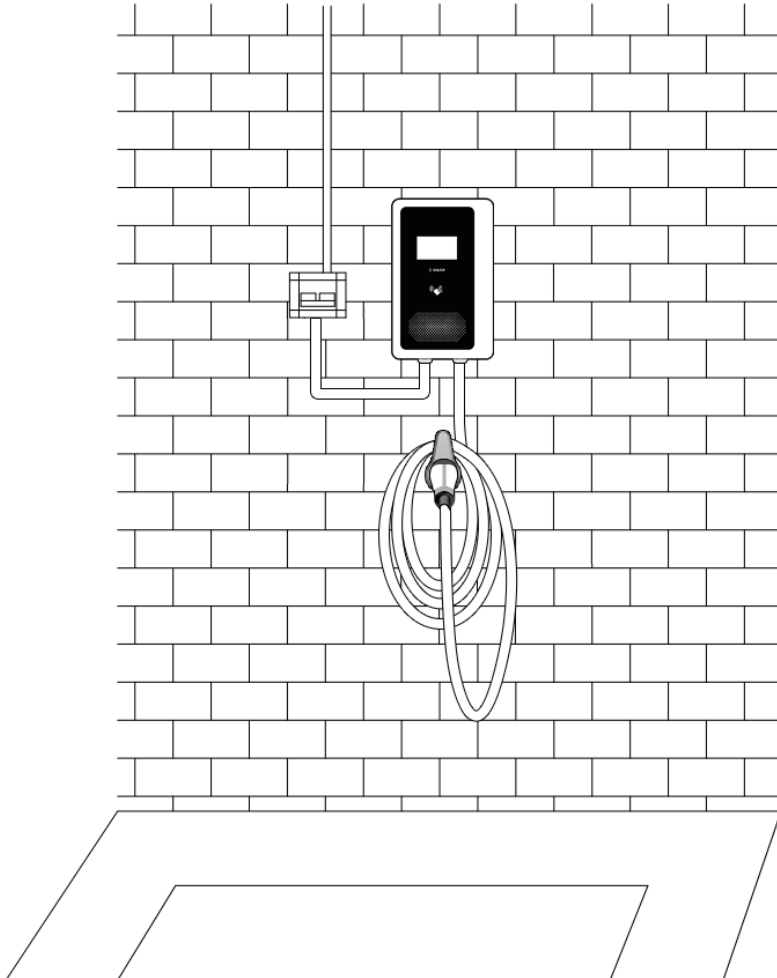

Fig. 7

After installation, the effect is as follows:



● Check and Debug the Device

1. Pre-operation check

Before running, please carefully check and ensure the following:

- 1) Ensure the EV charger is installed in a position to facilitate operation and maintenance.
- 2) Ensure the EV charger are connected to accessories properly and installed securely.
- 3) Ensure the selection of leakage protection switch of AC incoming line is reasonable.
- 4) No external objects or parts are left on top of the EV charger.

2. Power on the device

- 1) Confirm that the above pre-operation check items meet the requirements;
- 2) Close the power input leakage protection circuit breaker;
- 3) Power on, about 3 seconds startup self-check time, green indicator light flashes;
- 4) After the power-on self-test is complete, observe the LED indicator status and screen display.

3. Display interface

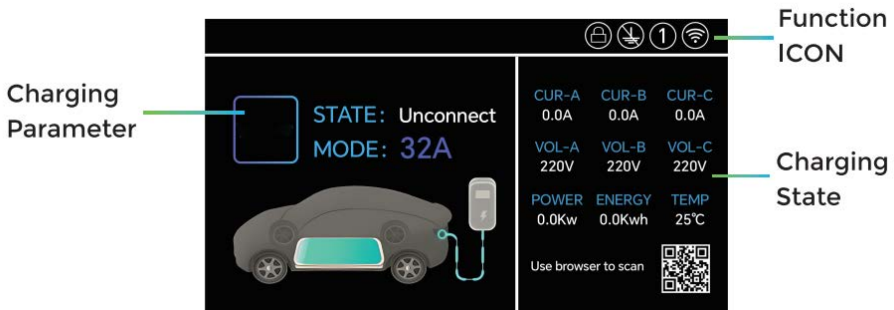

Charging Operation

1) Charging Connection

After the EV is parked, pull the cap of the vehicle connector lightly and completely, then insert the vehicle connector's head into your vehicle's outlet. Ensure the vehicle connector's head is fully inserted until it's locked.

2) Charge control

Stay for about 3 seconds to charge the electric car, in the card swiping area on the device panel, and the distance between the card and the card swiping area should be less than 2 mm.

* The device starts charging automatically, If "Auto-Start" is on (no small lock icon in the top right corner of the screen), charging starts automatically when the vehicle connector is inserted; If Auto-Start is switched off (there is a small lock icon in the top right corner of the screen), the phone needs to be connected to Wi-Fi for authorization to start charging.

3) Stop charging

Press the button and disconnect the vehicle connector from the vehicle inlet. then close the protective cap of EV and put on the protective cap of vehicle connector.

4) Use method of emergency stop button

Use emergency stop button: When you press the emergency stop button, the EV charger will stop working immediately.

How to restore: turn out the emergency stop button, and restart the EV charger with power off, and it will return to normal state.

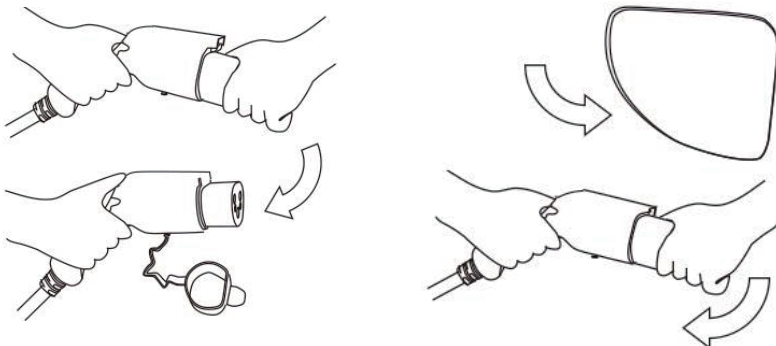

Wi-Fi Function Usage



1) Connect to Wi-Fi, turn on mobile Wi-Fi, search and connect to Wi-Fi name starting with RVD-, initial password: 12345678 (Note: the mobile phone cannot access the Internet after connecting to Wi-Fi);

 Note: If your phone prompts you that this network is not available, whether to use it or whether to switch, please choose to continue using it or not to allow switching.

2) Open the mobile browser (Mobile phone's own browser is recommended) and enter the "<http://192.168.4.1>" or use the browser scan code to open the web page;

 Tip: You can save this website as a bookmark, and next time you use it, open the browser after connecting to the charger Wi-Fi and click on the bookmark to open the web page. Some browsers also support adding bookmarks to the desktop. After connecting to the Charger Wi-Fi, we can simply click on the icon on the desktop to open the web page, just as convenient as using an APP.

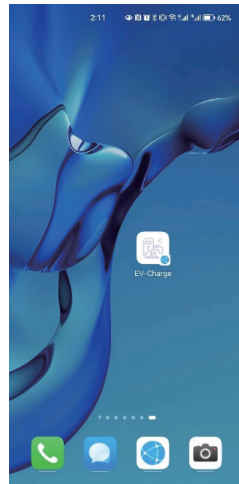
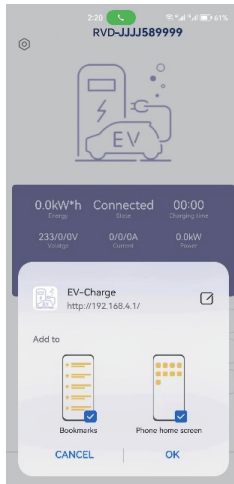
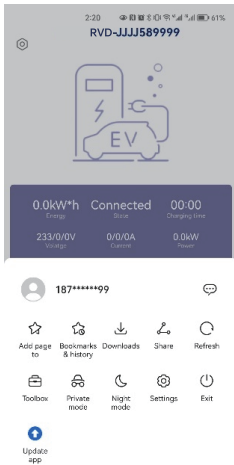

3) Setting

Click the setting icon in the upper left corner of the main page to enter the setting page, which can be set to charge, view/clear accumulated electricity, modify Wi-Fi connection password, etc.

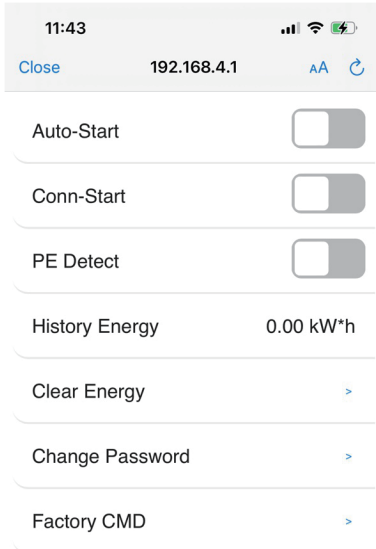

Auto-Start

① Turn on Auto-Start, you can plug and charge immediately.

② Set "Auto-start" off, the anti-theft charging function will be turned on. Then, plugging in the vehicle connector to start charging automatically is banned, you have to click the "Start" button in the web-control page to start charging.

Conn-start

When the Conn-Start is open, the mobile phone is connected to the charger hotspot(**required**), and the charging can be started automatically after inserting the charger.

PE Detect

To detect the power source you plug in if there is a ground wire. Make sure the circuit you use has the ground wire. If there is no ground wire, the LED indicator will turn red.

AUTO-START	CONN-START	CARD	
ON	OFF	OFF	No need to enter the web and no need to share the same Wi-Fi with the charger, just plug & go immediately.
OFF	OFF	OFF	Need to go to the web page and manually click "START" to turn on the charging.
OFF	ON	OFF	Share the same Wi-Fi with your charger, and you can charge without going to the web page.
OFF	OFF	ON	Swipe the card and start charging according to the parameters set in the previous charge.

4) Start charging with your phone:

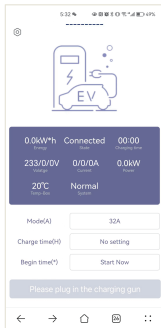

Home page



Current mode setting

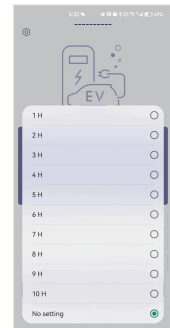

Set the charging limit time



Start charging

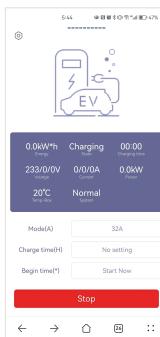

Charging

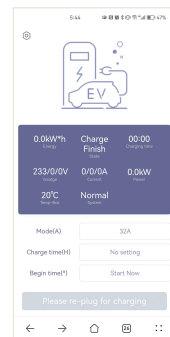

Stop charging

***Note: If you need to use your mobile phone to start or stop charging, please turn off "Auto-Start".**

5) Reservation

You can realize the reservation function by setting the “Begin time”. The setting steps are as follows:

- ① First insert the vehicle connector into the charging port.
- ② Then select the “Begin time” as required on the website.
- ③ When the countdown appears, the reservation is successful.

*Note:

To use the reservation function, you need to turn off “Auto-Start” and “Conn-Start”.

Some cars may not support the reservation function. If the reservation cannot be used normally, please set the “Begin time” to “Start Now”.

There is no need to swipe the card after setting the reservation.

The setting is only valid for a single time. The device will record the setting time. If you need to charge at the same time next time, click “Start” on the web page.

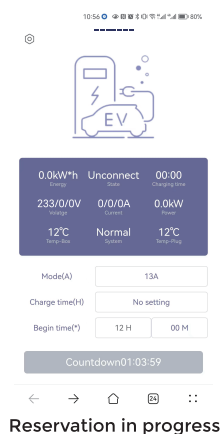
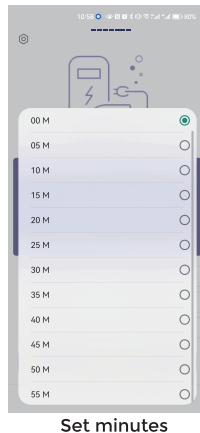
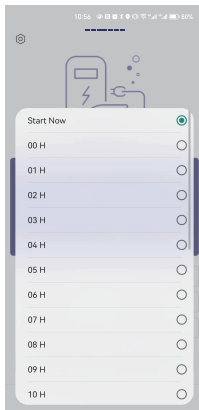

Charging **Status&Indicators**

Serial	charging state	Green	Blue	Red
1	UNCONNECT	off	Normally on	off
2	SWIPE CARD	Normally on	off	off
3	CARD PASS	Normally on	off	off
4	CHARGING	Breathing	off	off
5	EV STOP	Normally on	off	off
6	SWIPE STOP	Normally on	off	off
7	CP	off	off	Normally on
8	OV	off	off	Normally on
9	UV	off	off	Normally on
10	LEAK	off	off	Normally on
11	OC	off	off	Normally on
12	OT	off	off	Normally on
13	PE	off	off	Normally on

Troubleshooting

Error Codes	Reasons	Recommendation
CP	CP connection of vehicle connector is abnormal	<ol style="list-style-type: none"> 1. Check whether the vehicle connector is connected correctly and reliably. 2. If the fault persists, contact us.
PE	The input/output is improperly grounded	<ol style="list-style-type: none"> 1. Immediately turn off the leakage/over current protection switch of the distribution box. 2. Check whether the input/output lines of AC piles are grounded properly and whether the input L/N is connected in normal sequence. 3. After the fault is rectified, power on the device again. If the fault persists, contact us.

Error Codes	Reasons	Recommendation
OV	The AC input voltage is too high	<ol style="list-style-type: none"> 1. Please ask the electrician to test the input voltage of the air switch. 2. If the actual voltage exceeds 275Vac for a short time, wait for the network to restore itself to the normal voltage range, power off and restart. 3. If the actual voltage exceeds 275Vac for a long time, contact the power supply department. 4. If the actual voltage is less than 265Vac and the power failure is not recovered, please contact us.
UV	The AC input voltage is too low	<ol style="list-style-type: none"> 1. Please ask the electrician to test the input voltage of the air switch. 2. If the voltage is temporarily below 85Vac, wait for the voltage to return to normal range. 3. If the actual voltage is lower than 85Vac for a long time, contact the power supply department. 4. If the actual voltage is greater than 85Vac, please contact us.
OC	The AC input current is too large	<ol style="list-style-type: none"> 1. Immediately turn off the leakage/over current protection switch of the distribution box. 2. Check whether there is low impedance connection between two output lines of AC pile. 3. After troubleshooting the above problems, the power-on fails to recover, please contact us.
OT	The internal temperature is greater than 185°F	<ol style="list-style-type: none"> 1. Check the installation environment of AC piles. Check whether there are heating devices or devices nearby. Ensure that the ambient temperature is below 122°F. 2. If the fault cannot be rectified, please contact us.
LEAK	Leakage current is greater than 30mA	<ol style="list-style-type: none"> 1. Immediately turn off the leakage/over current protection switch of the distribution box. 2. Check AC pile output line for damage or low impedance connection to the ground. 3. After troubleshooting the above problems, reset the switch of leakage current protector and power on again. If the fault still exists, please contact us.



Make The Car Charging Safer

